

MECHANICAL SELF RE-TRACKING SWING GATES SW 021.010/SW 021.020

Swing gates with lockers SW 021.010/SW 021.020

The gate opens in one direction when the wing is pushed and then re-tracks back automatically and closes the entrance. The gate is equipped with a locker that blocks the wing in an open position. The gate should be mounted and the re-tracking speed regulated accordance to the user instructions. The equipment is intended to be used in closed places with firm floors. The system is mounted with three Ø8x120 screws and Ø12x100 pegs. Gates are made of steel and coated with nickel chromium.

Weight – approximately 12.5 kg

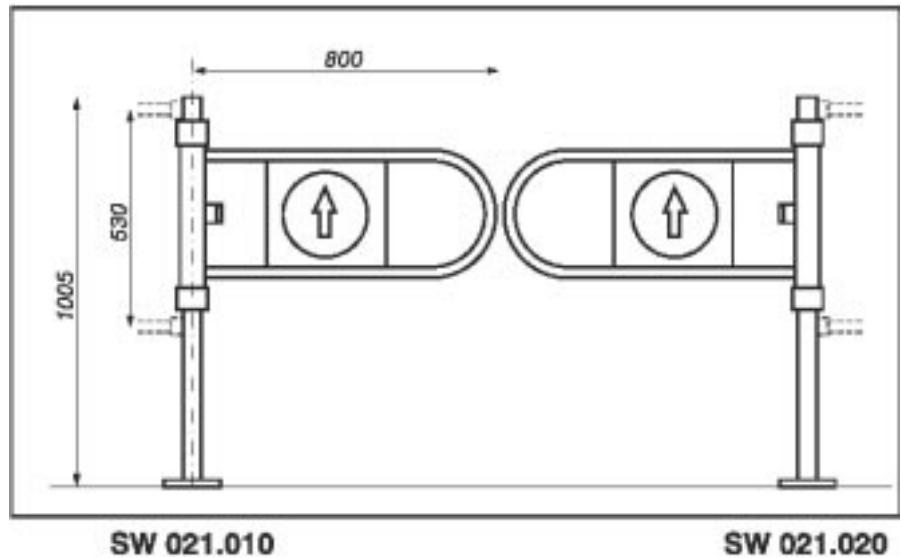

Left swing gate

Right swing gate

SW 021.010



SW 021.020



SW 021.011



SW 021.021



SW 021.012



SW 021.022



SW 021.013



SW 021.023



SW 021.014



SW 021.024



SW 021.015



SW 021.025



SW 021.016



SW 021.026



SW 021.017



SW 021.027

